

H PLANERS - THICKNESSERS



English



RF ROBLAND[®]
MADE IN BELGIUM

TABLE OF CONTENTS

About Robland	3 - 6
XSD310	7
NXSD310	8
NXSD410	9
SD410	10
SD510	11
KD410	12
D510	13
D630 EL	14
D630 X2	15
KS310	16
KS410	17
S410	18
J510	19
Differences NXSD & SD SERIES	20
Strengths	21
Cutter blocks	22 - 23
Options	24
Selection criteria	24 - 25
Robland machines overview	26 - 27
Disclaimer & contact details	28



MADE IN BELGIUM

SINCE 1968

ROBLAND is a privately owned Belgian company, that was founded in 1968 by Robert Landuyt. The first successes were achieved by building affordable qualitative universal woodworking machines, a large part of which are still in use today.

We do have all resources and competencies in house for product development, parts manufacturing, product assembly, sales and after sales support.

With our state of the art, highly automated, parts manufacturing machines we are able to remain cost effective while manufacturing in Belgium near the historical city of Bruges. Although our machines will last for years, this is not enough for us. A quality service and after sales support is key to ROBLANDs success. As we manufacture all machine parts ourselves, you can rely on spare parts always being rapidly available.

Our company mission is to offer woodworking machines with the best quality/price ratio to the high end Do-It-Yourself market and to the small and medium-sized enterprise market.

Our product portfolio, aimed at the second wood processing, includes panel saws, table saws, universal machines, planers, thicknessers, spindle moulders, horizontal mortisers, a semi-automatic boring machine, a CNC boring machine, edgebanders and dust extraction systems.

We have an international dealer network and currently export over 85% of our production worldwide to more than 100 countries. In its 20.000 m² large factory ROBLAND employs over 80 people.

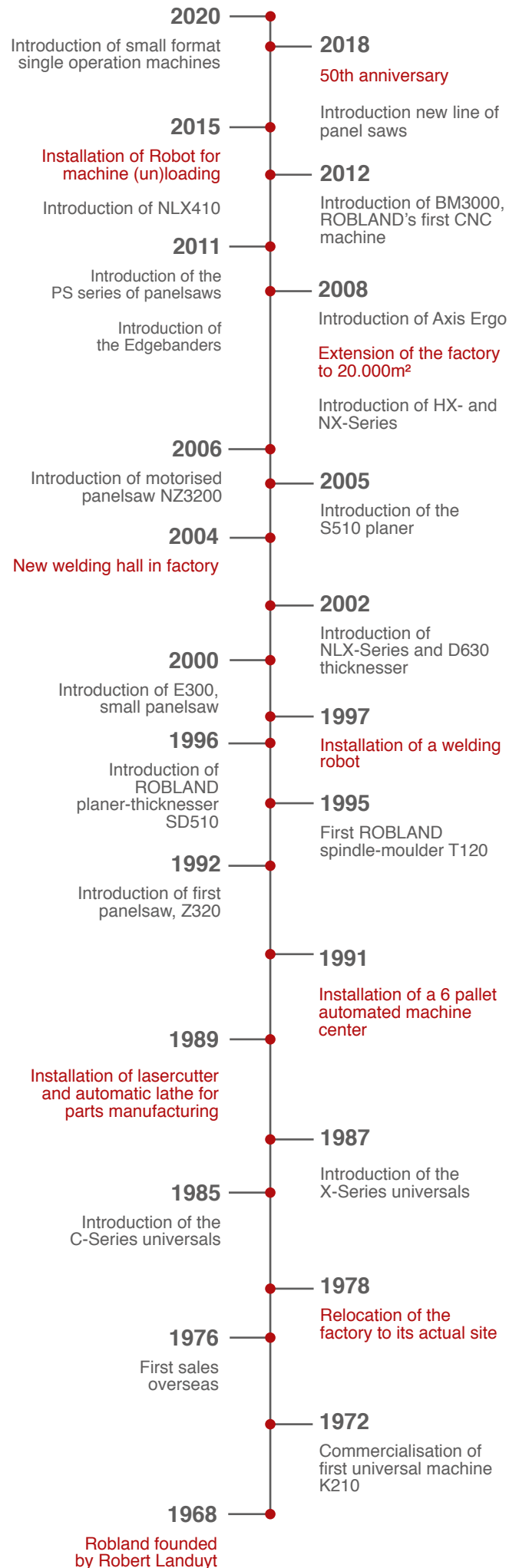

PRODUCTION



Surface scraping of cast iron table



Raw steel bars



Steel plate laser cutting



Milling of drive roll



Computer assisted steel plate bending



Machining parts



Welding of frame



Machining parts



Powder coating



Part picking by robot

SUBASSEMBLY

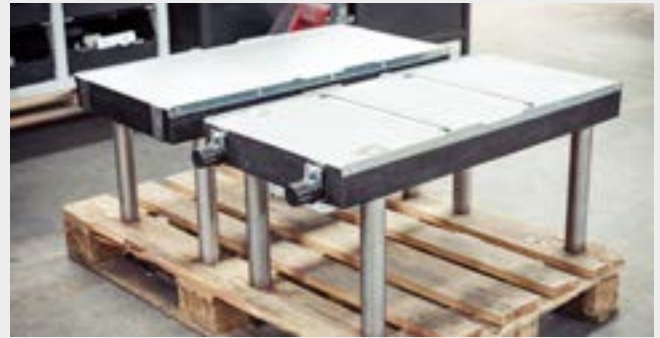
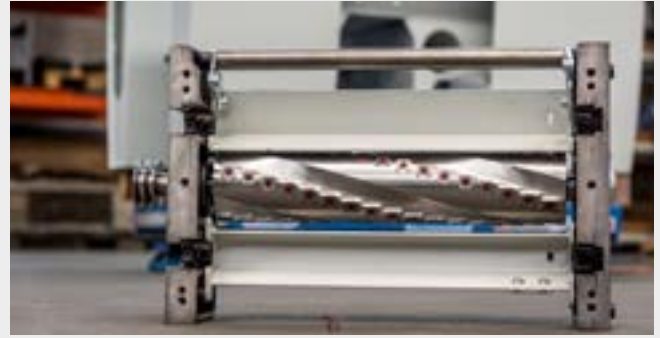

ASSEMBLY



LEVELLING AND ALIGNMENT OF THE TABLES





For 50 years, an enthusiastic team has been working daily on the future of the company and of that of our customers. Meanwhile, Robland is an international player, but personal contacts still remain incredibly important.

Gert Muijs, CEO



Rudy and Ruben work at Robland's department of design. This department has short lines of communication with both the department of parts production and machine assembly, which ensures great flexibility. Robland is focusing on standardising the machinery parts, aiming for a better customer service.



Kenneth has been working at Robland for almost 10 years. He appreciates the large variation in his job and is proud to work for a company that is 100% Belgian. Kenneth works at the milling department, which uses both vertical and horizontal milling cutters.



Robland has different assembly lines that each can be divided into different phases. **Sven** is team leader of the combination line, which has four different phases, just like the other assembly lines. Pre-assembly is important to make sure the entire process runs smoothly.



Marin is responsible for checking the quality of the machinery at Robland. These quality checks are conducted by random sampling checks. Marin also provides training for the distributors of the Robland machinery.



Robland never sells directly to the end-consumers. As such, the target audience is reached via dealers and importers, with which our commercial team collaborates tightly. According to commercial manager **Tom Borghmans** "Robland has collaborated with most dealers and importers for over 30 years, creating good and sustainable relations."



Mark has been our warehouse manager at Robland since 1989. He optimises the loading of machines in trucks and containers and also handles the shipment of spare parts. Mark is amazed by Robland's worldwide fame and the ability to deliver to the most remote places.



With a lot of passion for wood, **Evvy** has studied for wood-worker and is now working at our department of technical support. She creates YouTube movies about the factory and/or Robland machines and provides demonstrations for customers. Evvy can regularly be found at fairs all around the globe.

XSD310



XSD310 with options

XSD310 Technical Data

Weight	250 kg
Voltage	230 V Mono / 400 V - 3
Phase	
Motor power 3 phase (S6)	3 kW / 4 hp
Motor power single phase (S6)	2,2 kW / 3 hp
Dust suction outlet	100 mm

Planer

Planer width	310 mm
Total length planer tables	1328 mm
Diameter cutter block	70 mm
Number of knives	3
Dimensions knives	310 x 25 x 3 mm
Rotation speed	5400 RPM
Dimensions planer fence	1300 x 150 mm
Inclination planer fence	90° - 45°
Max. depth of cut	4 mm

Thicknesser

Dimensions thicknesser table	430 x 310 mm
Height capacity thicknesser	230 mm
Diameter feed rollers	30 mm
Max. depth of cut	4 mm
Feeding speed	6 m/min.

Mortiser (option)

Chuck	0 - 16 mm
Travel	165 x 140 x 85 mm

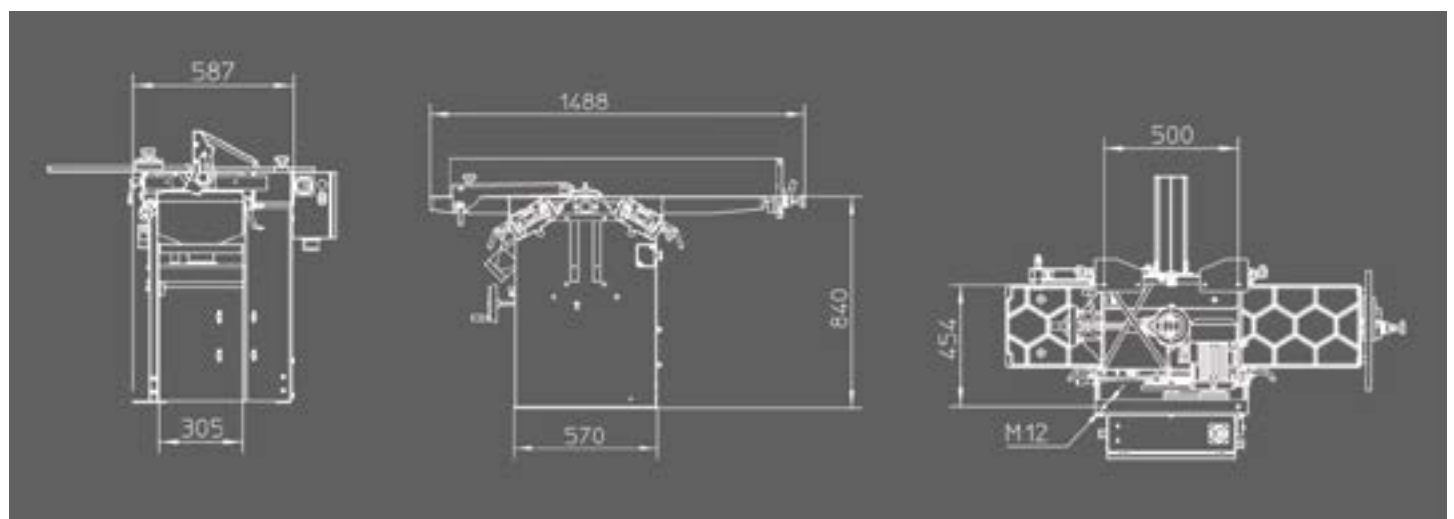

NXSD310



NXSD310 with options

NXSD310 Technical Data

Weight	280 kg
Voltage	230 V Mono
	230 V - 3 Phase
	400 V - 3 Phase
Motor power 3 phase (S6)	3,72 kW / 5 hp
Motor power single phase (S6)	2,2 kW / 3 hp
Dust suction outlet	100 mm

Planer

Planer width	310 mm
Total length planer tables	1400 mm
Diameter cutter block	70 mm
Number of knives	3
Dimensions knives	310 x 25 x 3 mm
Rotation speed	5500 RPM
Dimensions planer fence	1300 x 150 mm
Inclination planer fence	90° - 45°
Max. depth of cut	4 mm

Thicknesser

Dimensions thicknesser table	430 x 310 mm
Height capacity thicknesser	230 mm
Diameter feed rollers	30 mm
Max. depth of cut	4 mm
Feeding speed	6 m/min.

Mortiser (Option)

Chuck	0 - 16 mm
Travel	165 x 140 x 85 mm

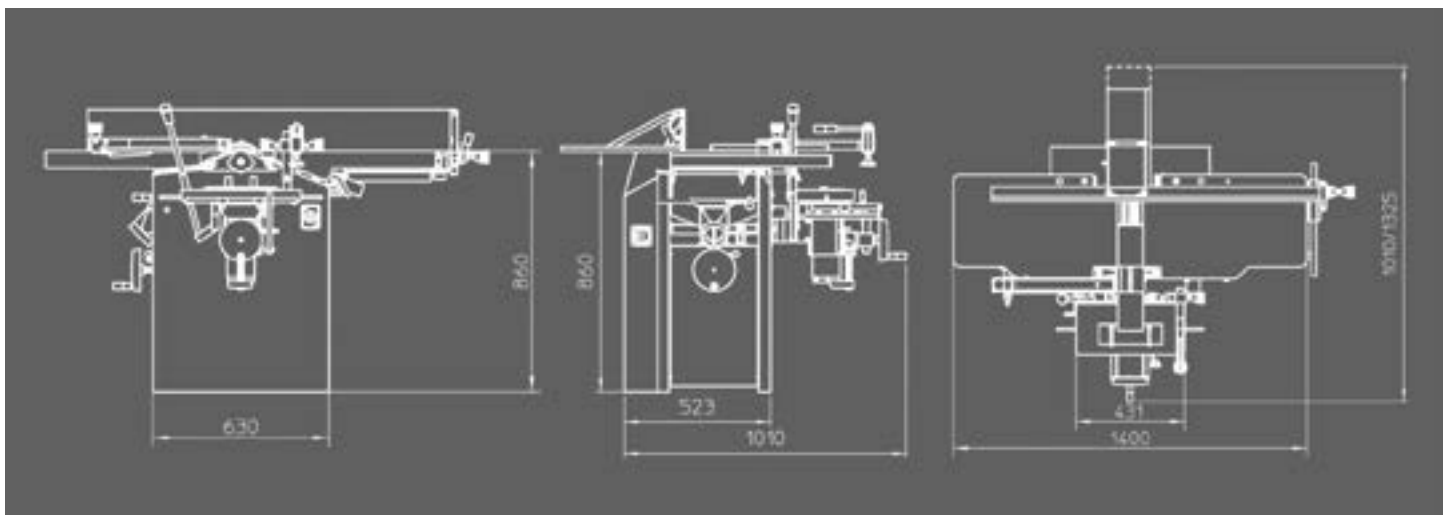

NXSD410



NXSD410 with options

NXSD410 Technical Data

Weight	350 kg
Voltage	230 V Mono
	230 V - 3 Phase
	400 V - 3 Phase
Motor power 3 phase (S6)	4,85kW / 6,6 hp
Motor power single phase (S6)	2,2 kW / 3 hp
Dust suction outlet	100 mm

Planer

Planer width	410 mm
Total length planer tables	1800 mm
Diameter cutter block	70 mm
Knives	3
Dimensions knives	410 x 25 x 3 mm
Rotation speed	5500 RPM
Dimensions planer fence	1500 x 150 mm
Inclination planer fence	90° - 45°
Max. depth of cut	4 mm

Thicknesser

Dimensions thicknesser table	600 x 410 mm
Height capacity thicknesser	230 mm
Diameter feed rollers	30 mm
Max. depth of cut	4 mm
Feeding speed	6 m/min.

Mortiser (Option)

Chuck	0 - 16 mm
Travel	165 x 140 x 85 mm

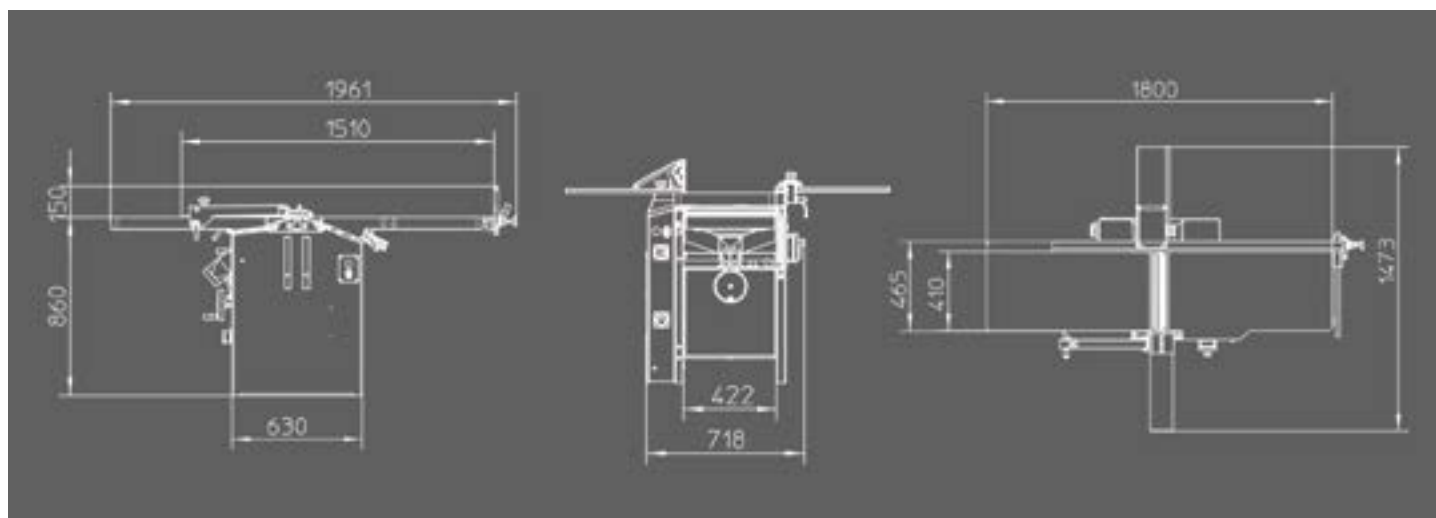

SD410



SD410 with options

SD410 Technical data

Weight	615 kg
Voltage	3 x 400 V
	3 x 220 V
Motor power (S6)	4,4 kW / 6,6 hp (option 7 kW)
Dust extraction diameter	120 mm
Diameter cutter block	90 mm
Knives	4
Dimensions knives	410 x 25 x 3 mm
Cutter block rotation speed	5500 RPM
Max. depth of cut	4 mm

Planer

Planer width	410 mm
Total length planer tables	2000 mm
Dimensions planer fence	1350 x 200 mm
Inclination planer fence	90° - 45°

Thicknesser

Thicknesser width	410 mm
Height capacity thicknesser	3 - 250 mm
Dimensions thicknesser table	870 x 410 mm
Feeding speed	6 m/min.
Feeding speed with comfort pack	6 / 12 m/min.
Diameter feed rollers	40 mm

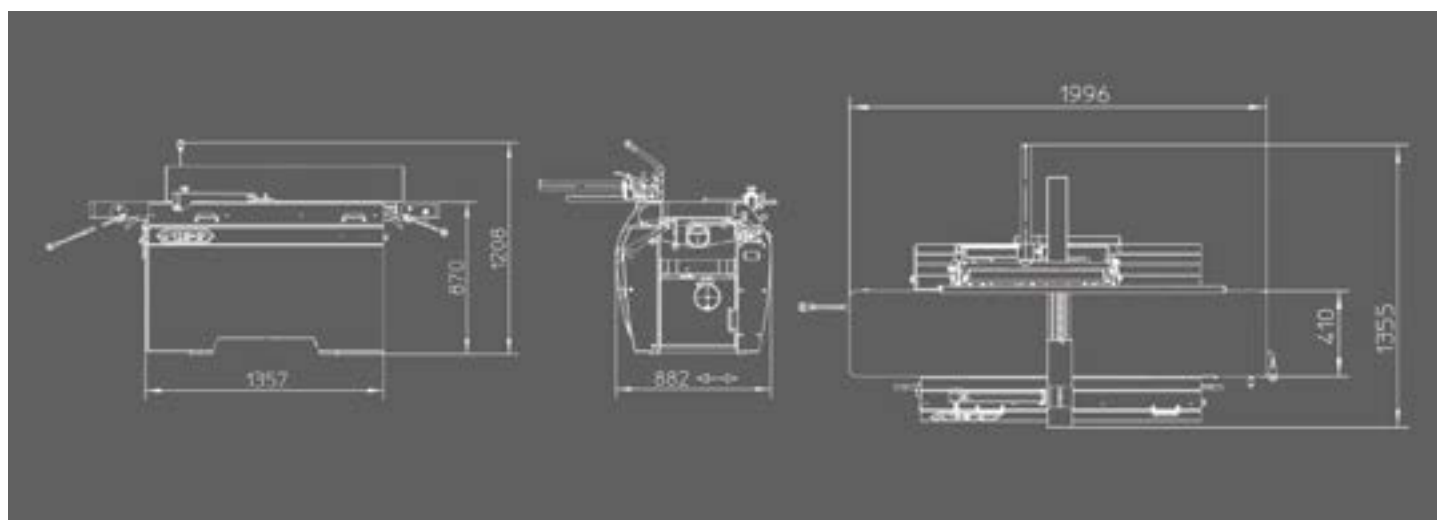

SD510



SD510 with options

SD510 Technical data

Weight	900 kg
Voltage	3 x 400 V
	3 x 220 V
Motor power (S6)	7 kW / 9,5 hp (option 9,2 kW)
Dust extraction diameter	120 mm
Diameter cutter block	100 mm
Knives	4
Dimensions knives	510 x 30 x 3 mm
Cutter block rotation speed	6000 RPM
Max. depth of cut	6 mm

Planer

Planer width	510 mm
Total length planer tables	2250 mm
Dimensions planer fence	1350 x 200 mm
Inclination planer fence	90° - 45°

Thicknesser

Thicknesser width	510 mm
Height capacity thicknesser	3 - 250 mm
Dimensions thicknesser table	1050 x 510 mm
Feeding speed	8 / 16 m/min.
Feeding speed with comfort pack	5 / 8 / 10 / 16 m./min.
Diameter feed rollers	50 mm

Mortiser (option)

Dimensions table	600 x 300 mm
Chuck	0 - 16 mm
Travel	200 x 150 x 150 mm
Rotation speed	3000 RPM

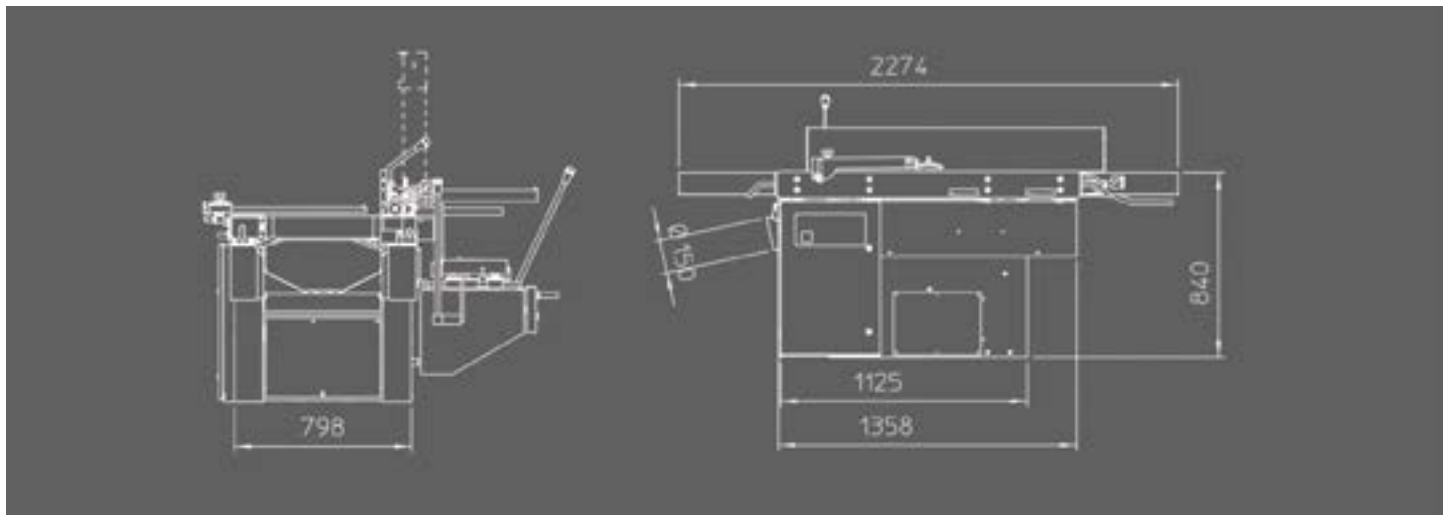

KD410



KD410 with options

KD410 Technical data

Weight	205 kg	Thicknesser width	410 mm
Voltage	230 V Mono	Height capacity thicknesser	230 mm
	230 V - 3 Phase	Dimensions thicknesser table	600 x 410 mm
	400 V - 3 Phase	Feeding speed	6 m/min.
Motor power (S6) - Mono	2,2 kW / 3 hp	Diameter feed rollers	30 mm
Motor power (S6) - 3Phase	4,85 kW / 6,6 hp		
Dust extraction diameter	100 mm		
Diameter cutter block	70 mm		
Knives	3		
Dimensions knives	410 x 25 x 3 mm		
Rotation speed	5500 RPM		
Max. depth of cut	4 mm		

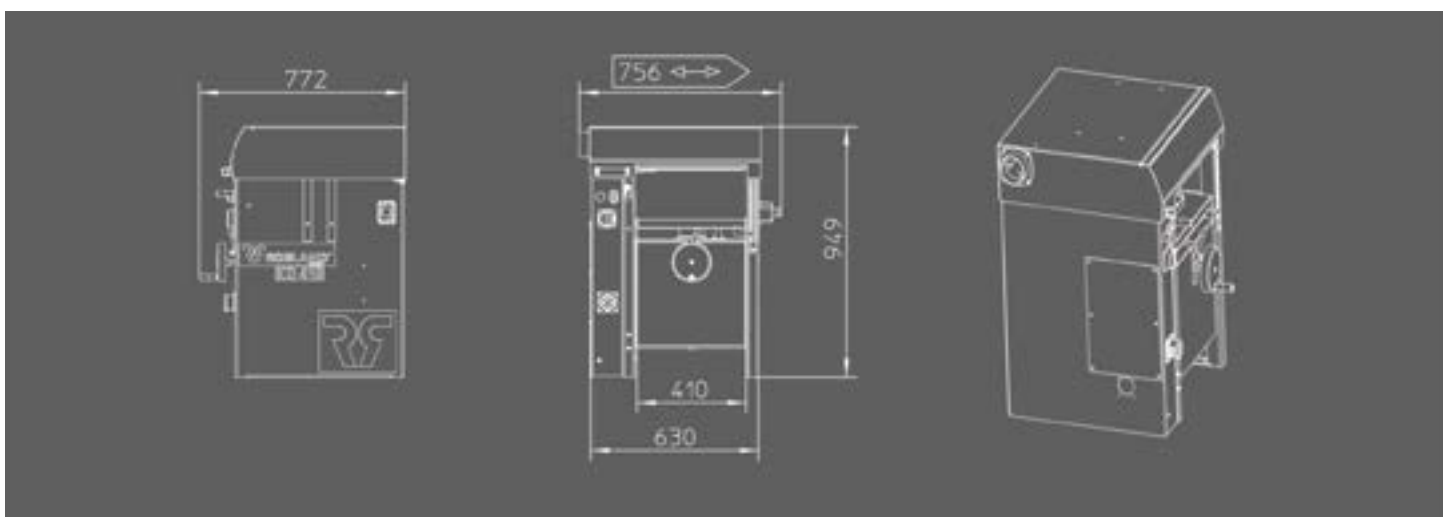

D510



D510 with options

D510 Technical data

Weight	650 kg	Thicknesser width	510 mm
Voltage	3 x 400 V	Height capacity thicknesser	3 - 250 mm
	3 x 230 V	Dimensions thicknesser table	1050 x 510 mm
Motor power (S6)	7 kW / 9,5 hp (option 9,2 kW)	Feeding speed	8 / 16 m/min.
Dust extraction diameter	120 mm	Feeding speed with comfort pack	5 / 8 / 10 / 16 m./min.
Diameter cutter block	100 mm	Diameter feed rollers	50 mm
Knives	4		
Dimensions knives	510 x 30 x 3 mm		
Rotation speed	6000 RPM		
Max. depth of cut	6 mm		

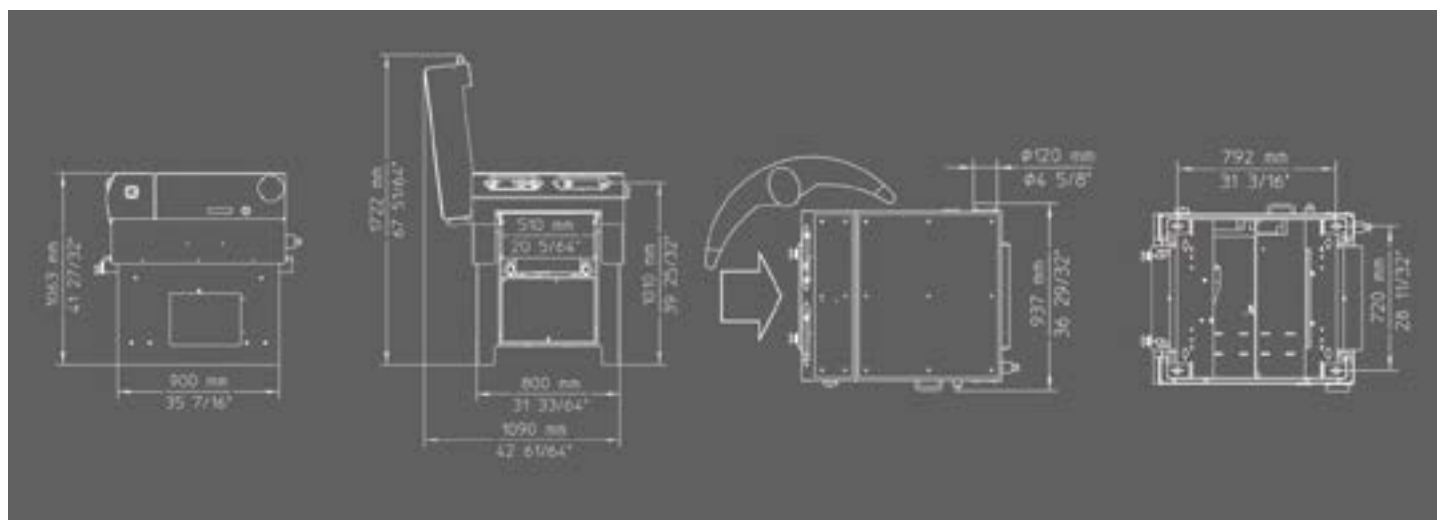

D630 EL



D630 EL with options

D630 EL Technical data

Weight	950 kg
Voltage	3 x 400 V
	3 x 230 V
Motor power (S6)	9,2 kW / 12 hp
Dust extraction diameter	120 mm
Diameter cutter block	120 mm
Knives	4
Dimensions knives	630 x 30 x 3 mm
Rotation speed	5200 RPM
Max. depth of cut	8 mm
Thickener width	630 mm
Height capacity thickener	3 - 300 mm
Dimensions thickener table	1160 x 630 mm
Variable feeding speed	5 - 22 m/min.
Diameter feed rollers	70 mm

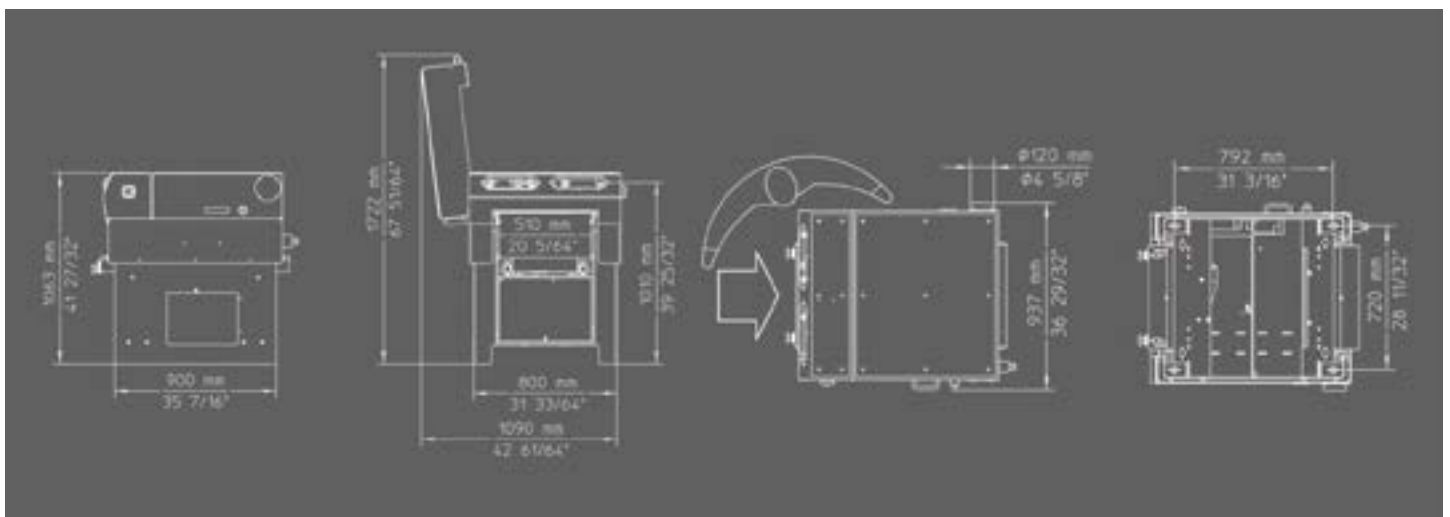

D630 X2



D630 X2 with options

D630 X2 Technical data

Weight	950 kg
Voltage	3 x 400 V
	3 x 230 V
Motor power (S6)	9,2 kW / 12 hp
Dust extraction diameter	120 mm
Diameter cutter block	120 mm
Knives	4
Dimensions knives	630 x 30 x 3 mm
Rotation speed	5200 RPM
Max. depth of cut	8 mm
Thicknesser width	630 mm
Height capacity thicknesser	3 - 300 mm
Dimensions thicknesser table	1160 x 630 mm
Variable feeding speed	5 - 22 m/min.
Diameter feed rollers	70 mm

Touch screen panel for numerical control of thickness and feeding speed.

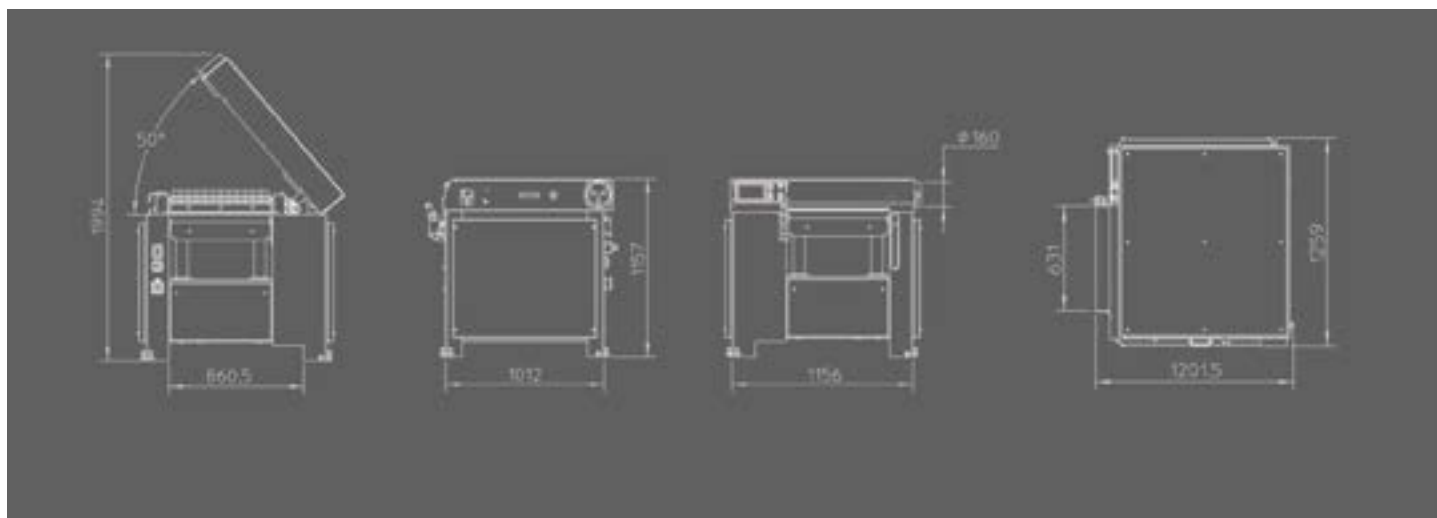

KS310



KS310 with options

KS310 Technical data

Weight	250 kg	Width of planor arbor	310 mm
Voltage	230 V Mono	Diameter planer arbor	70 mm
	400 V - 3 Phase	Dimensions planing fence	1300 x 150 mm
Motor power (S6) Mono	2,2 kW / 3 hp	Tilting planing fence	90° - 45°
Motor power (S6) - 3 Phase	3,7 kW / 5 hp	Max. chip removal per pass	4 mm
Dust extraction diameter	100 mm	Total length of planing tables	1400 mm
Knives	3		
Dimensions knives	310 x 25 x 3 mm		
Rotation speed	5500 RPM		

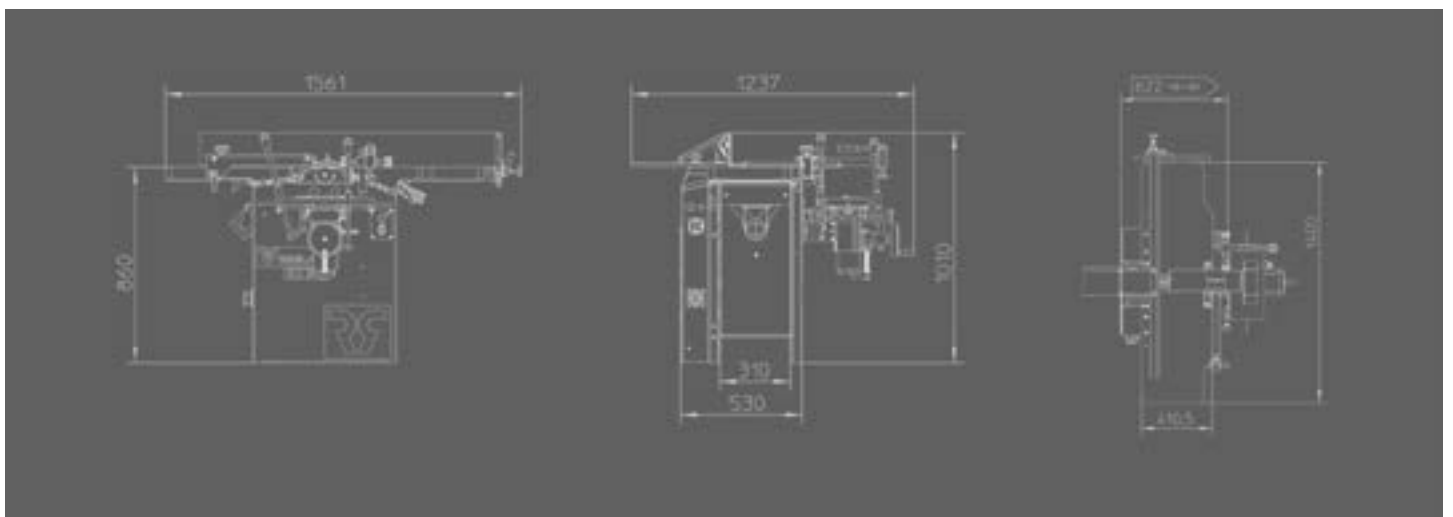

KS410



KS410 with options

KS410 Technical data

Weight	295 kg	Width of planor arbor	410 mm
Voltage	230 V Mono	Diameter planer arbor	70 mm
	230 V - 3 Phase	Dimensions planing fence	1500 x 150 mm
	400 V - 3 Phase	Tilting planing fence	90° - 45°
Motor power (S6) Mono	2,2 kW / 3 hp	Max. chip removal per pass	4 mm
Motor power (S6) - 3 Phase	4,85 kW / 6,6 hp	Total length of planing tables	1800 mm
Dust extraction diameter	100 mm		
Knives	3		
Dimensions knives	410 x 25 x 3 mm		
Rotation speed	5500 RPM		

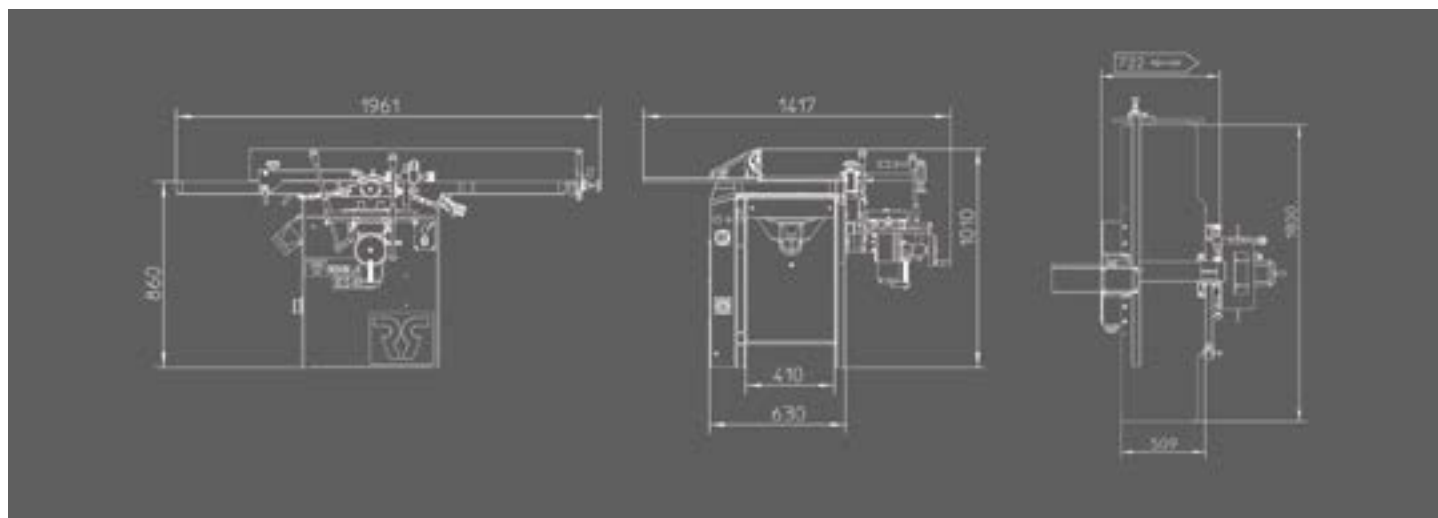

S410



S410 with options

S410 Technical data

Weight	475 kg
Voltage	3 x 400 V
	3 x 230 V
Motor power (S6)	4,4 kW / 6,6 hp (option 7 kW)
Dust extraction diameter	120 mm
Diameter cutter block	90 mm
Knives	4
Dimensions knives	410 x 25 x 3 mm
Rotation speed	5500 RPM
Max. depth of cut	4 mm

Planer width	410 mm
Total length planer tables	2360 mm
Dimensions planer fence	1350 x 200 mm
Inclination planer fence	90° - 45°

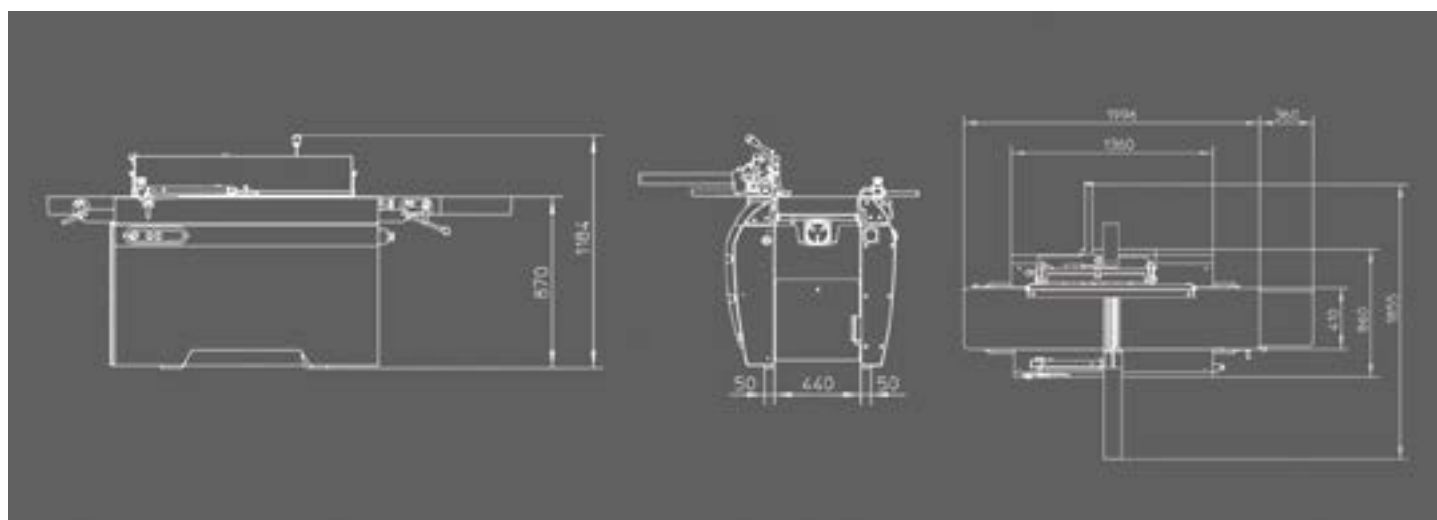

J510



J510 with options

J510 Technical data

Weight	800 kg
Voltage	3 x 400 V
	3 x 230 V
Motor power (S6)	7 kW / 9,5 hp (option 9,2 kW)
Dust extraction diameter	120 mm
Diameter cutter block	100 mm
Knives	4
Dimensions knives	510 x 30 x 3 mm
Rotation speed	6000 RPM
Max. depth of cut	6 mm

Planer width	510 mm
Total length planer tables	2630 mm
Dimensions planer fence	1350 x 200 mm
Inclination planer fence	90° - 45°

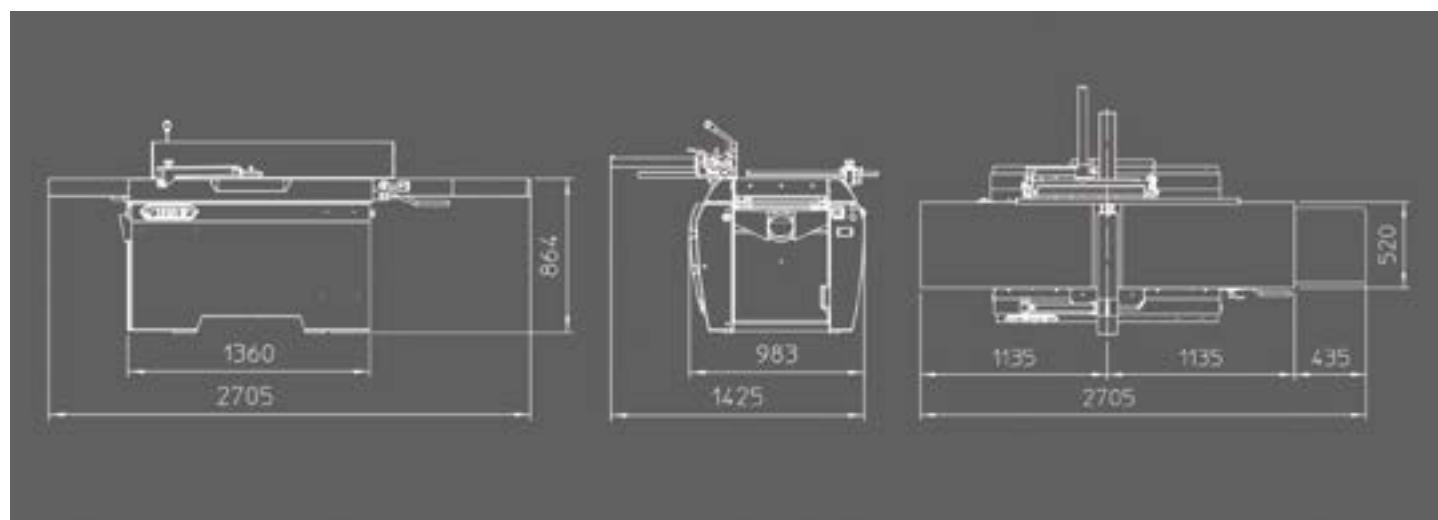

DIFFERENCES BETWEEN NXSD & SD SERIES

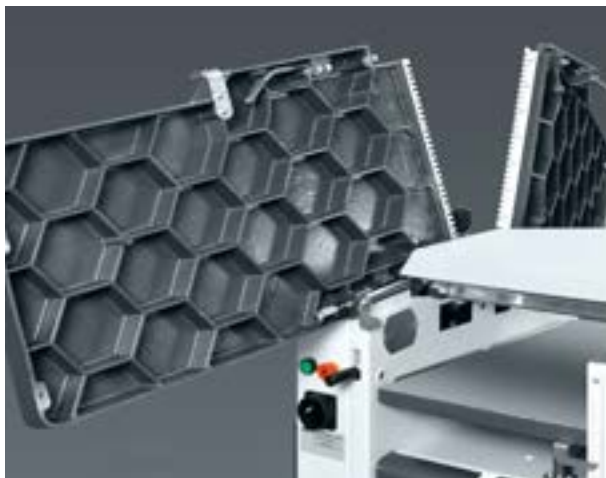

ON NXSD

The heavy cast iron tables on the NXSD models open up in butterfly wings to allow for easy access to the thicknesser despite of the the long planer tables.



ON SD410 & SD510

Strong springs allow the easy handling of the very heavy cast iron planer tables on the SD410 and SD510.

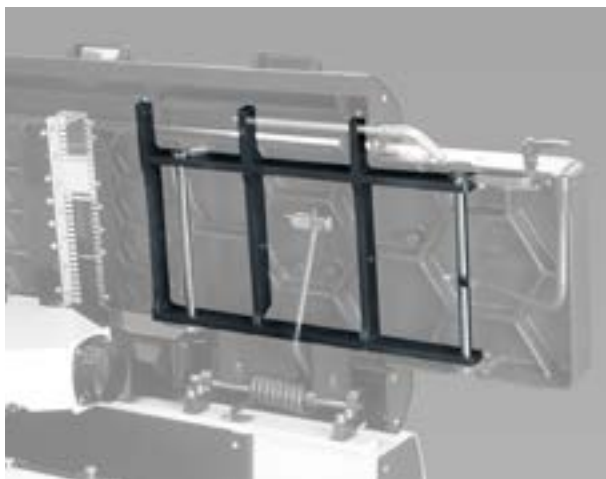

SUPPORTING FRAME

In comparison to our competitors we have a bigger supporting frame under the tables which covers the complete in- and outfeed table and which makes the tables even stronger and more rigid.

STRENGTHS

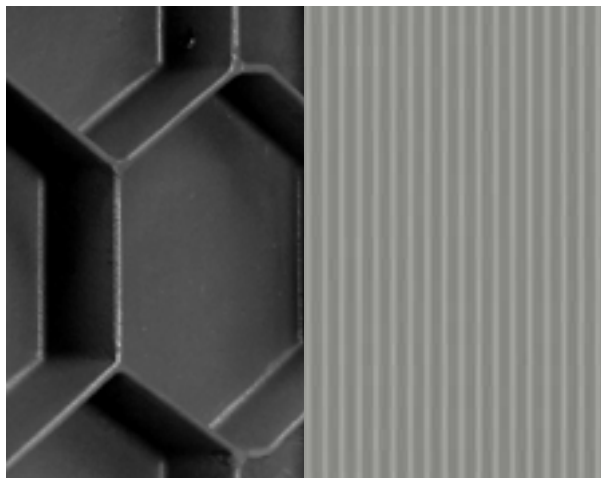

CAST IRON TABLES

Our cast iron tables have a honeycomb structure for the highest strength per weight ratio. The surface is scraped. This technique with low energy dissipation guarantees a very flat surface. Micro-grooves are applied for easy gliding of the wooden work piece on the cast iron table.



STABLE THICKNESSER TABLE

On D510, D630, SD410 and SD510 four heavy pillars support the thicknesser table ensuring a horizontal position of the table even under heavy, uneven load.

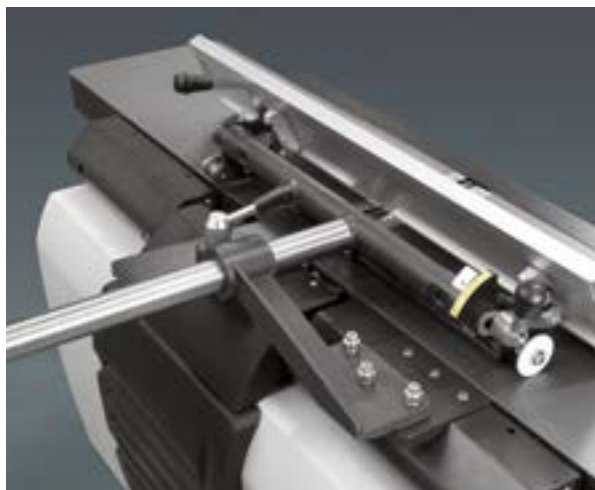

PLANER FENCE (ON THE SD410, SD510, S410 & J510)

The large and sturdy aluminium planer fence can be tilted to any angle between 45° and 90°.

DIFFERENT CUTTER BLOCKS



STANDARD CUTTER BLOCK

For most people this cutter block offers the best price/quality ratio. The blades can be resharpened and are easy to replace thanks to a specific toolset, delivered with the machine.



TERSA CUTTER BLOCK

The machine can be equipped with a TERSA system, to allow for a fast exchange of the knives. The disposable TERSA blades are available in a wide selection to fit different types of wood.

The TERSA cutter block has a slightly lower noise level than the standard block.



SPIRAL CUTTER BLOCK

When processing hard wood types the spiral cutter block has a lower noise level and consumes less energy than a standard cutter block. The blades also typically last longer.

On hard wood the 3 rows of knives result in a high quality finishing.

OPTIONS

NXSD / KD SERIE



HANDWHEEL WITH INTEGRATED ANALOGUE READ-OUT THICKNESSER TABLE (ON THE NXSD)

Handwheel with integrated analogue readout for the thicknesser table. This mechanical readout offers even more comfort and precision than the standard ruler.

SD / S / D SERIE



SUVAMATIC

The spring-mechanism on the SuvaMatic safety-hood guarantees sure that the cutter block is only revealed on the part needed to work with.

SECTIONAL INFEEED ROLLER (D630)

With the sectional infeed roller it is possible to simultaneously feed different pieces with a thickness difference of maximum 2 mm. It is also possible to consistently feed one piece having a variation of maximum 2 mm in thickness over its width and/or length.



COMFORT PACK SD SERIE

- Digital read-out thicknesser table
- Additional feed speeds on thicknesser (4 speeds)
- Table extension thicknesser table (on SD410 only)
- Auxiliary fence for planning narrow workpieces
- Foldable protection on the planer



COMFORT PACK D510

- 4 feed speeds
- Digital read-out thicknesser table



ACCESSORIES

WHEEL SET

With the wheel system consisting of two fixed wheels at one side and a swiveling wheel with steering handle at the other, you can easily move your machine. (available on the KD410, KS410, NXSD310 and NXSD410)



MORTISING UNIT ON NXSD

The smooth and easy to operate unit can be removed from the machine within minutes. It also has 2 detachable handles, easy when machining large workpieces.



MORTISING UNIT ON SD510

The smooth and easy to operate heavy duty mortising unit has a speed reduction to 3000 RPM. It also has 2 handles to move the heavy cast iron table easily. The chuck capacity is from 0 to 16 mm.



PLANER - THICKNESSER

OVERVIEW

	XSD310	NXSD310	NXSD410	SD410	SD510
Machines basics					
Planer width (mm)	310	310	410	410	510
Thicknesser width (mm)	310	310	410	410	510
Manual rise and fall thicknesser table	X	X	X	X	-
Electrical rise and fall thicknesser table	-	-	-	X	X
Min passage thicknesser					
3 mm	X	X	X	X	X
Max passage thicknesser					
230 mm	X	X	X	-	-
250 mm	-	-	-	X	X
300 mm	-	-	-	-	-
Max. depth of cut	4 mm	4 mm	4 mm	4 mm	6 mm
Motor powers (S6 - 40% Duty cycle)					
3 kW * 400 V	X	-	-	-	-
single phase 2,2 kW	O	O	-	-	-
3,7 kW 3 * 400 V	X	X	-	-	-
3,7 kW 3 * 220 V	-	O	-	-	-
4,4 kW 3 * 400 V	-	-	X	X	-
4,4 kW 3 * 220 V	-	-	-	O	O
7 kW 3 * 400 V	-	-	-	O	X
7 kW 3 * 220 V	-	-	-	O	O
9,2 kW 3 * 400 V	-	-	-	-	O
9,2 kW 3 * 220 V	-	-	-	-	O
14 kW 3 * 400 V	-	-	-	-	-
Spindle diameter					
70 mm	X	X	-	-	-
90 mm	-	-	X	X	-
100 mm	-	-	-	-	X
120 mm	-	-	-	-	-
Length planer tables					
1400 mm	X	X	-	-	-
1800 mm	-	-	X	-	-
2000 mm	-	-	-	X	-
2250 mm	-	-	-	-	X
2360 mm	-	-	-	-	-
2630 mm	-	-	-	-	-
Number of knives standard					
3	X	X	X	-	-
4	-	-	-	X	X
Number of knives Tersa					
3	O	O	O	-	-
4	-	-	-	O	O
Number of knives spiral					
52	O	O	-	-	-
68	-	-	O	O	-
88	-	-	-	-	O
108	-	-	-	-	-
Number of columns under thicknesser					
1 + 1 guidance	X	X	X	-	-
4	-	-	-	X	X
Digital read-outs					
Height thicknesser	-	-	-	O	O
Feed speeds thicknesser					
5 m/min.	-	-	-	-	O
6 m/min.	X	X	X	X	-
8 m/min.	-	-	-	-	X
10 m/min.	-	-	-	-	O
12 m/min.	-	-	-	O	-
16 m/min.	-	-	-	-	X
22 m/min.	-	-	-	-	-

KD410	D510	D630	KS310	KS410	S410	J510
-	-	-	310	410	410	510
410	510	630	-	-	-	-
X	-	-	-	-	-	-
-	X	X	-	-	-	-
X	X	X	-	-	-	-
X	-	-	-	-	-	-
-	X	-	-	-	-	-
-	-	X	-	-	-	-
4 mm	6 mm	8 mm	4 mm	4 mm	4 mm	6 mm
-	-	-	-	-	-	-
-	-	-	O	O	-	-
O	-	-	X	-	-	-
-	-	-	O	-	-	-
-	-	-	-	X	X	-
X	-	-	-	O	O	-
-	X	-	-	-	O	X
-	O	-	-	-	O	O
-	O	X	-	-	-	O
-	O	O	-	-	-	O
-	-	O	-	-	-	-
-	-	-	X	X	-	-
X	-	-	-	-	X	-
-	X	-	-	-	-	X
-	-	X	-	-	-	-
-	-	-	X	-	-	-
X	-	-	-	X	-	-
-	-	-	-	-	-	-
-	-	-	-	-	-	-
-	-	-	-	-	X	-
-	-	-	-	-	-	X
X	-	-	X	X	-	-
-	X	X	-	-	X	X
O	-	-	O	O	-	-
-	O	O	-	-	O	O
-	-	-	O	-	-	-
O	-	-	-	O	O	-
-	O	-	-	-	-	O
-	-	O	-	-	-	-
X	-	-	-	-	-	-
-	X	X	-	-	-	-
-	O	O	-	-	O	O
-	O	continuous variable	-	-	-	-
X	-	continuous variable	-	-	-	-
-	X	continuous variable	-	-	-	-
-	O	continuous variable	-	-	-	-
-	-	continuous variable	-	-	-	-
-	X	continuous variable	-	-	-	-
-	-	continuous variable	-	-	-	-

PANEL SAWS



NXZ



E300



CZ SERIES



FZ SERIES



Z400 SERIES



Z500 SERIES

PLANER - THICKNESSERS



NXSD310



SD410



SD510

PLANERS



KS410



S410



J510

THICKNESSERS



D510



D630

HORIZONTAL SLOT MORTISER



LBM

SPINDLE - MOULDERS



KBM



KT30 PRO



T120S



T120L



T120P



M500

COMBINED MACHINES



HX260



HX310 PRO



NX310/410 PRO



NLX310/410 PRO



NXTZ PRO



NLXTZ PRO

DRILLING MACHINES



BM21 PRO



BM3000



KM575

EDGEBANDERS



This brochure is for information purposes only. Robland reserves the right to modify machine configurations and specifications without prior notice. Standard configurations can change over time and by point of purchase. Please consult your local dealer for accurate and up to date information.

Robland NV
Kolvestraat 44
8000 Brugge - Belgium
Tel: +32 50 458 925
info@robland.com
www.robland.com



Follow us on Facebook
www.facebook.com/Roblandmachines



Follow us on Instagram
www.instagram.com/robland_nv



Follow us on YouTube
www.youtube.com/robland